

## Master Tug TMS TMS30/1650

---

The Trailer moving system is a versatile electric tug designed for moving lorry trailers through the manufacturing process and service centres. The Master Tug TMS connects to the fifth wheel Pin lifting the front of the trailer off its stands, and steers 180 degrees so difficult parking can be made easy. The compact size of the tug allows modern stage production process methods to be used while creating a safer working environment.

### Benefits

---

- Moves loads up to 11000 kg
- Takt time production process
- No waiting for tractor units
- No more diesel fumes inside
- More production space
- Improved safety

### Key Features

---

- Speed and performance of the tug can be specified by the customer
- The Trailer Moving System rotates either side of the trailer allowing it to be rotated through 90 degrees if required
- Sealed to work in adverse conditions



Master Tug TMS TMS30/1650

## Technical Data - Master Tug TMS TMS30/1650

### Identification

Product Code	TMS30/1650
Maximum Recommended Load Weight	11000 kg
Drive Type	Electric
Braking	Regenerative
Parking Brake	Electromagnetic
Operation	Pedestrian
Steering	Manual
Standard Colour	Yellow
Maximum Trailer Weight	11000 kg

### Weight

Machine Weight (Excluding Battery)	450 kg
Standard Battery Weight	250 kg

### Wheels

Drive Wheel Type	Polyurethane
Drive Wheel Shore Hardness	92 sh
Support Castors	Reinforced Ductile Steel

### Mast

Connection Type	Hydraulic
Maximum Weight Transfer	2400 kg
Maximum Side Loading	2000 kg
Hydraulic Motor	2200 w
Standard Coupling Type	Steel 5th Wheel

### Power Output

Drive Motor Power	3 kW DC
Gearbox type	Planetary
Controller Type	Series Wound DC
Maximum Programmable Speed	5 kph
Standard Power Source	24 Volt 210A/H Flooded

### Charging

Standard Charger Type	Wall Mounted Microprocessor
Mains Input Supply	220 - 240 V
Standard Output	30 A
Re-charge Time	8 h

## Dimensions - Master Tug TMS TMS30/1650

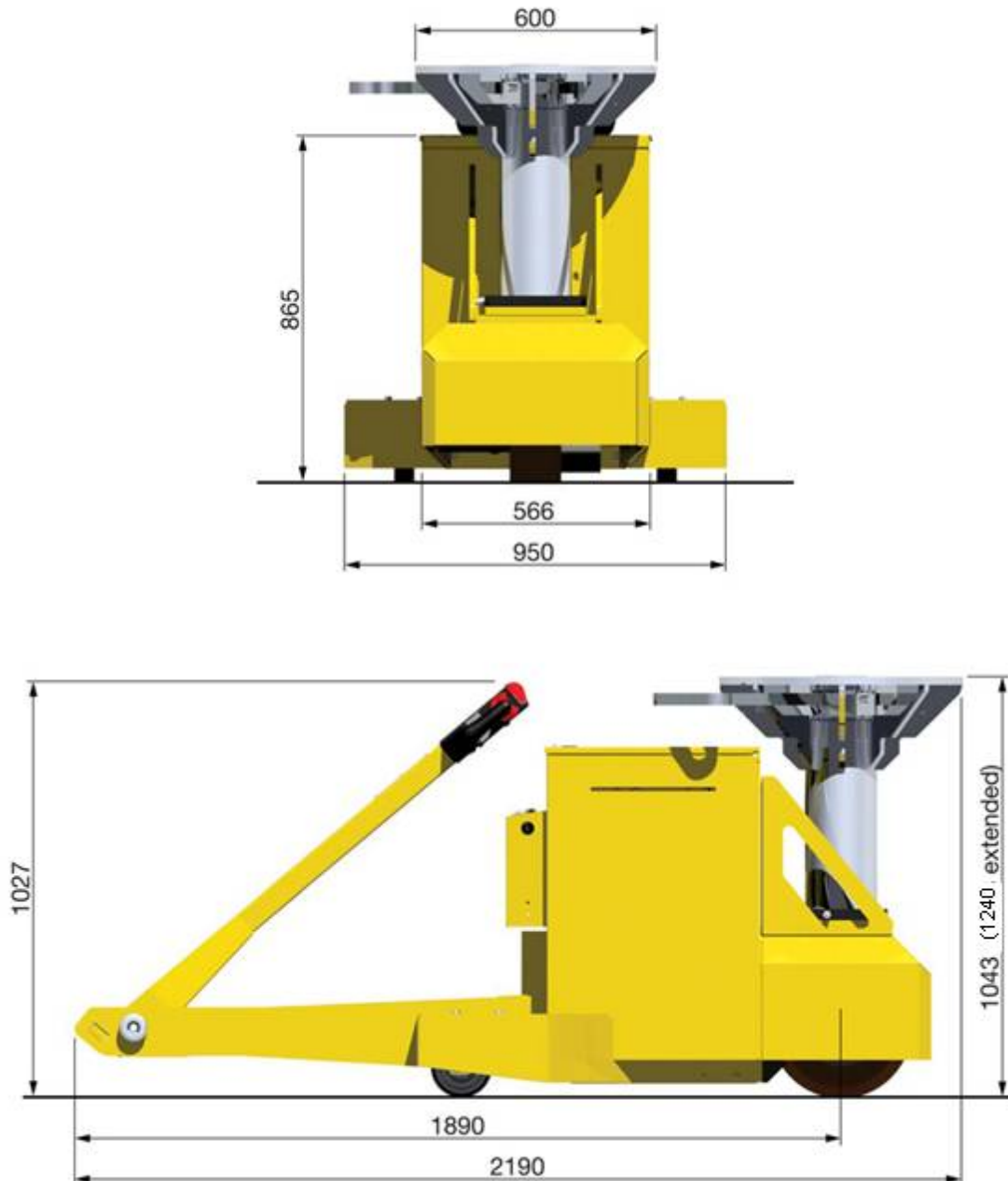

# MasterMover®

World leader in pedestrian operated tugs

## Our full product range of handling solutions

---

MasterMover Ltd have been designing and manufacturing pedestrian electric tugs for over a decade. Traction, power and safety are all standard features of our electric tugs which enables their use in all industries. They eliminate manual handling, improve Health & Safety and increase productivity. MasterMover can move wheeled and semi wheeled loads ranging from 50 to 100,000 kg and with an innovative range there is a machine to suit all applications. We offer full warranty, After Sales Service and Flexible Contract Hire options on all machines.



**MasterMover Ltd** - Registered in England No. 6776797

**Registered Office:**

Moor Farm Road, Airfield Industrial Estate, Ashbourne, Derbyshire, DE6 1HD, United Kingdom.  
MasterMover® All Rights Reserved ©2009 MasterMover Ltd.